

HR-1200 Cáncamo Giratorio Lateral

Load Rated

HR-1200



- Amplia gama de capacidades disponible:
 - 650 libras a 29,000 libras
 - Tamaños métricos de 0.3 ton a 13 ton.
- Los componentes del cuerpo son de acero de aleación y templados y revenidos.
- Tasada a 100% de su Capacidad de Carga en ángulos hasta 90°.
- Cada pieza es estampada con un Código de Identificación de Producción (PIC) para la rastreabilidad del material, y con el Límite de Carga de Trabajo, y el nombre Crosby® ó "CG".
- El cuerpo del cáncamo es suministrado con un acabado de cromato amarillo que mejora la resistencia a la corrosión.
- Utiliza grilletes estándar Crosby para conectar cable de acero ó fibra sintética. (vendidos por separado)
- Múltiples longitudes de pernos disponibles para satisfacer sus requerimientos.
- Carga de Prueba individual de 2-1/2 veces la carga de Trabajo.
- Todos los tamaños son EQUIPADOS CON RFID.



VER INFORMACION SOBRE APLICACION Y ADVERTENCIAS

Para Español: www.thecrosbygroup.com

En las páginas 202-203

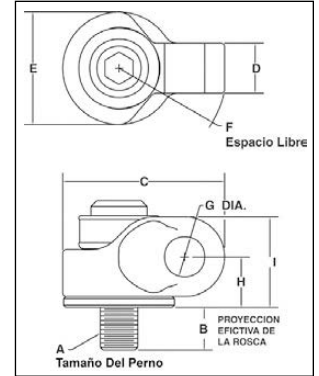

HR-1200 Cáncamos Giratorios Laterales UNC

Peso de c/u (lbs)	Carga límite de trabajo (lbs)*	HR-1200 No. de parte	Torque en Pie-lbs	(A) Tamaño del Perno	(B) Largo efectivo de proyección de la rosca (pulg)	Dimensiones (pulg.)							Grilletes recomendados			
						C	D	E	F	Dia. G	H	I	Grilletes perno rojo 209,210,213, 215,2130,2150		Grilletes perno rojo para banda S-281	
													Tamaño nominal (in)	Carga límite de trabajo (t)	Ancho Fibra (plg)	Carga límite de trabajo (t)
.35	650	1067700	7	5/16-18x1.50	.59	1.93	.72	1.00	1.56	.80	.85	1.43	1/2, 5/8	2, 3-1/4	2	3-1/4
.36	800	1067704	12	3/8-16x1.50	.59	1.93	.72	1.00	1.56	.80	.85	1.43	1/2, 5/8	2, 3-1/4	2	3-1/4
1.4	2000	1067708	28	1/2-13x2.00	.71	2.97	.97	2.00	2.13	.93	1.07	1.79	5/8, 3/4	3-1/4, 4-3/4	2, 1.5	3-1/4, 4-1/2
1.4	2000	1067712	28	1/2-13x2.50	1.21	2.97	.97	2.00	2.13	.93	1.07	1.79	5/8, 3/4	3-1/4, 4-3/4	2, 1.5	3-1/4, 4-1/2
1.5	3000	1067716	60	5/8-11x2.00	.71	2.97	.97	2.00	2.13	.93	1.07	1.79	5/8, 3/4	3-1/4, 4-3/4	2, 1.5	3-1/4, 4-1/2
1.5	3000	1067720	60	5/8-11x2.75	1.46	2.97	.97	2.00	2.13	.93	1.07	1.79	5/8, 3/4	3-1/4, 4-3/4	2, 1.5	3-1/4, 4-1/2
4.5	5000	1067724	100	3/4-10x2.75	.90	4.32	1.34	3.00	3.00	1.07	1.35	2.42	7/8	6-1/2	2	6-1/4
4.6	5000	1067728	100	3/4-10x3.50	1.65	4.32	1.34	3.00	3.00	1.07	1.35	2.42	7/8	6-1/2	2	6-1/4
4.6	6500	1067732	160	7/8-9x2.75	.90	4.32	1.34	3.00	3.00	1.07	1.35	2.42	7/8	6-1/2	2	6-1/4
4.8	6500	1067736	160	7/8-9x3.50	1.65	4.32	1.34	3.00	3.00	1.07	1.35	2.42	7/8	6-1/2	2	6-1/4
4.8	8000	1067740	230	1-8x3.00	1.15	4.32	1.34	3.00	3.00	1.07	1.35	2.42	7/8	6-1/2	2	6-1/4
5.0	8000	1067744	230	1-8x4.00	2.15	4.32	1.34	3.00	3.00	1.07	1.35	2.42	7/8	6-1/2	2	6-1/4
10.2	14000	1067748	470	1-1/4-7x4.5	2.22	5.59	1.57	3.75	3.91	1.47	1.92	3.42	1, 1-1/8, 1-1/4	8-1/2, 9-1/2, 12	3	8-1/2
23.5	17200	1067756	800	1-1/2-6x6.5	2.98	7.31	2.06	4.75	5.19	2.11	2.41	4.29	1-3/8, 1-1/2, 1-3/4	13-1/2, 17, 25	-	-
25.3	29000	1067764	1100	2-4.5x6.5	2.98	7.31	2.06	4.75	5.19	2.11	2.41	4.29	1-3/8, 1-1/2, 1-3/4	13-1/2, 17, 25	-	-

*La Carga de Ruptura es 5 veces la Carga Limite de Trabajo.

HR-1200M Cáncamos Giratorios Laterales Métricos

Peso de c/u (lbs)	Carga límite de trabajo (kg.)*	HR-1200M No. de parte	Torque en Pie (Nm)	(A) Tamaño del Perno	(B) Largo efectivo de proyección de la rosca (mm)	Dimensiones (mm)							Grilletes recomendados			
						C	D	E	F	Dia. G	H	I	Grilletes perno rojo 209,210,213, 215,2130,2150		Grilletes perno rojo para banda S-281	
													Tamaño nominal (plg)	Carga límite de trabajo (t)	Ancho Fibra (plg)	Carga límite de trabajo (t)
.18	300	1067803	10	M8x1.25x40	16.9	49.0	18.3	25.4	39.6	20.3	21.6	36.3	1/2, 5/8	2, 3-1/4	2	3-1/4
.18	400	1067807	16	M10x1.50x40	16.9	49.0	18.3	25.4	39.6	20.3	21.6	36.3	1/2, 5/8	2, 3-1/4	2	3-1/4
.63	1000	1067811	38	M12x1.75x50	17.2	75.4	24.6	50.8	54.1	23.6	27.2	45.5	5/8, 3/4	3-1/4, 4-3/4	2, 1.5	3-1/4, 4-1/2
.68	1400	1067815	81	M16x2.0x60	27.2	75.4	24.6	50.8	54.1	23.6	27.2	45.5	5/8, 3/4	3-1/4, 4-3/4	2, 1.5	3-1/4, 4-1/2
2.0	2250	1067823	136	M20x2.5x75	28.1	110	34.0	76.2	76.2	27.2	34.4	61.5	7/8	6-1/2	2	6-1/4
2.2	3500	1067827	312	M24x3.0x80	33.1	110	34.0	76.2	76.2	27.2	34.4	61.5	7/8	6-1/2	2	6-1/4
4.5	6250	1067831	637	M30x3.5x120	65.1	142	39.9	95.3	99.3	37.3	48.8	86.9	1, 1-1/8, 1-1/4	8-1/2, 9-1/2, 12	3	8-1/2
10.4	7750	1067835	1005	M36x4.0x150	60.6	186	52.3	121	132	53.6	61.2	109	1-3/8, 1-1/2, 1-3/4	13-1/2, 17, 25	-	-
10.7	10000	1067839	1005	M42x4.5x160	70.6	186	52.3	121	132	53.6	61.2	109	1-3/8, 1-1/2, 1-3/4	13-1/2, 17, 25	-	-
11.0	13000	1067843	1350	M48x5.0x160	70.6	186	52.3	121	132	53.6	61.2	109	1-3/8, 1-1/2, 1-3/4	13-1/2, 17, 25	-	-

*La Carga de Ruptura es 5 veces la Carga Limite de Trabajo.